

**SIDE VIEW**

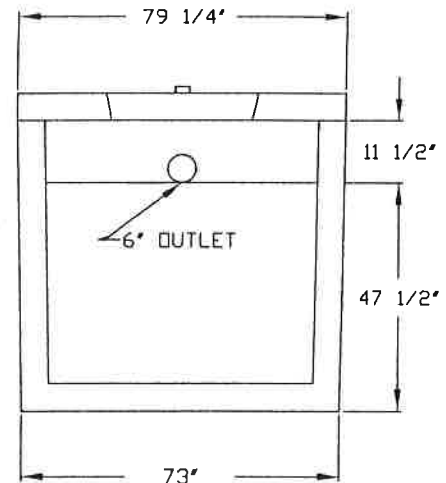

**END VIEW**

TANK: CATEGORY 4. 6" 1530 GALLON 1 COMPARTMENT TANK REINFORCED WITH #4 STEEL 12" O/C. BOTH WAYS. 6" WALLS AND 6" BOTTOM. INLET AND OUTLET RESILIENT CONNECTORS PER ASTM-923-98. CONNECTORS MUST BE USED WITH APPROVED CLAMP. CONNECTOR WILL ACCEPT 6" PVC PIPE.

LIDS: 5" LID WITH 1-22" ROUND MANHOLE COVER AT EACH END OF TANK  
 8" LID WITH 1-22" ROUND MANHOLE COVER AT EACH END OF TANK  
 BOTH LIDS ARE REINFORCED WITH GRADE 60 REBAR.

TANK & LIDS: 4000 PSI CONCRETE AT 28 DAYS

IMPRINTED ON INLET END OF TANK:

LEGEND: FSI1530 STATE APPROVAL: 01-011-28P-C4

WEIGHTS: TANK ONLY 16,654  
 TANK W/ 5" LID 20,866  
 TANK W/ 8" LID 25,078

THIS TANK IS RATED FOR H-20 LOADING WHEN USED WITH 8" TRAFFIC LID AND TANK BURIAL DEPTH IS AT LEAST 18" BELOW GROUND SURFACE.

THIS TANK COMPLIES WITH SECTION 1003.5 OF THE 2007 FLORIDA PLUMBING CODE.

INTERCEPTOR CAPACITY PER 1003.5.1 IS SITE SPECIFIC.

THIS SEWAGE TREATMENT RECEPACLE HAS BEEN DESIGNED, CONSTRUCTED AND STRUCTURALLY TESTED IN ACCORDANCE WITH CHAPTER 64E-6.013, FLORIDA ADMINISTRATIVE CODE, (FAC) DATED APRIL 28, 2010.

DRAWING NOT TO SCALE

**FLORIDA SEPTIC, INC.**

P.O. BOX 545  
 HAWTHORNE, FLORIDA 32640  
 (800) 940-8265

MODEL:  
 6" 1530 GAL. TANK

REVISED:  
 05/01/2011

APPROVAL DATE:  
 02/28/2011